



商用一体式方冰制冰机  
COMMERCIAL SELF-CONTAINED CUBER

# 使用说明书 INSTRUCTION MANUAL

**IM-30CBZ**  
**IM-30CBZ-25**  
**IM-45CBZ**  
**IM-45CBZ-25**  
**IM-65BZ**  
**IM-65BZ-25**  
**IM-100BZ**  
**IM-100BZ-23**  
**IM-130BZ**  
**IM-130BZ-23**

- 使用手册是本产品不可分割的重要组成部分，用户须妥善保管。
- 请务必仔细阅读本手册中描述的指南和警告事项，因为这些指南和警告事项为安装人员/用户提供了正确安装、持续安全地使用和保养本产品所需的重要信息。
- 请妥善保管本手册，以便必要时参考使用。
- This booklet is an integral and essential part of the product and should be kept and preserved by the user.
- Please read carefully the guidelines and warnings contained herein as they are intended to provide the installer/user with essential information for the proper installation and the continued safe use and maintenance of the product.
- Please preserve this booklet for any further consultation that may be necessary.

生产商：**星崎商厨智造(苏州)有限公司**  
Manufacturer: **HOSHIZAKI CHINA CORPORATION**

L1M033304 (122225)

---

## 中文

重要安全须知 .....	1
I. 安装说明 .....	2
1. 构造 .....	2
2. 附件 .....	2
3. 拆包 .....	3
4. 位置 .....	4
5. 安装 .....	4
6. 电气连接 .....	4
7. 供水和排水连接 .....	5
II. 操作说明 .....	6
1. 启动 .....	6
2. 长时间不使用制冰机时 .....	6
III. 保养 .....	7
1. 清洁 .....	7
2. 联系维修机构前 .....	9
3. 废弃处理 .....	9
4. 保修 .....	9
规格 .....	10

## ENGLISH

IMPORTANT SAFETY INFORMATION .....	11
I. INSTALLATION INSTRUCTIONS .....	12
1. CONSTRUCTION .....	12
2. ACCESSORIES .....	12
3. UNPACKING .....	13
4. LOCATION .....	14
5. INSTALLATION .....	14
6. ELECTRICAL CONNECTIONS .....	14
7. WATER SUPPLY AND DRAIN CONNECTIONS .....	15
II. OPERATING INSTRUCTIONS .....	16
1. START UP .....	16
2. PREPARING THE ICEMAKER FOR LONG STORAGE .....	16
III. MAINTENANCE .....	17
1. CLEANING .....	17
2. BEFORE CALLING FOR SERVICE .....	19
3. DISPOSAL .....	19
4. WARRANTY .....	19
SPECIFICATIONS .....	20

## 重要安全须知

本说明书提供可能导致死亡、严重受伤或损坏设备的注意事项，请用户使用时注意。

<b>▲警告</b>	表示如不可避免，则可能导致死亡或严重受伤的危险情况。
<b>▲小心</b>	表示如不可避免，则可能导致轻微受伤或中度受伤的危险情况。
<b>注意</b>	表示如不可避免，则可能导致本设备损坏的危险情况。
<b>▲卫生</b>	表示与卫生和食品安全相关的重要预防措施。
<b>重要</b>	表示与使用和维护本设备相关的重要信息。

<b>▲警告</b>
<p>本制冰机为商用设备，仅适用于该设备所明确设计的用途。 其它任何用途都被视为不当用途，因而可能造成危险。对因本产品使用不当、使用不正确和不合理所造成的的任何损失，生产商不承担法律责任或相关责任。</p>
<p><b>安装及必要时的移机作业，必须交由具备相应知识的作业人员依照现行法规并根据生产商的说明进行。</b></p>
<p>保持机体内外通风口畅通无阻。</p>
<p>使用任何电气设备均应遵循一些基本规则，尤其是：</p> <ul style="list-style-type: none"> <li>* 高湿度和潮气会加大电路短路及潜在触电的危险。如有可疑情况，请切断制冰机电源。</li> <li>* 将制冰机与供电网络断开时，请勿损坏或拉扯电源线。</li> <li>* 请勿用湿手触碰电气部件或操作开关。</li> <li>* 本产品不适合残障、智障及缺乏相应经验和知识的人士(包括儿童)单独使用，除非有专人负责其安全，并对其使用本产品加以监督和指导。</li> <li>* 另外还应对幼童加以看管，以确保其不玩耍本产品。</li> <li>* 请勿尝试改装制冰机。应仅由具备相应知识的作业人员实施拆解或维修作业。</li> </ul>

# 中文

## I. 安装说明

### 1. 构造

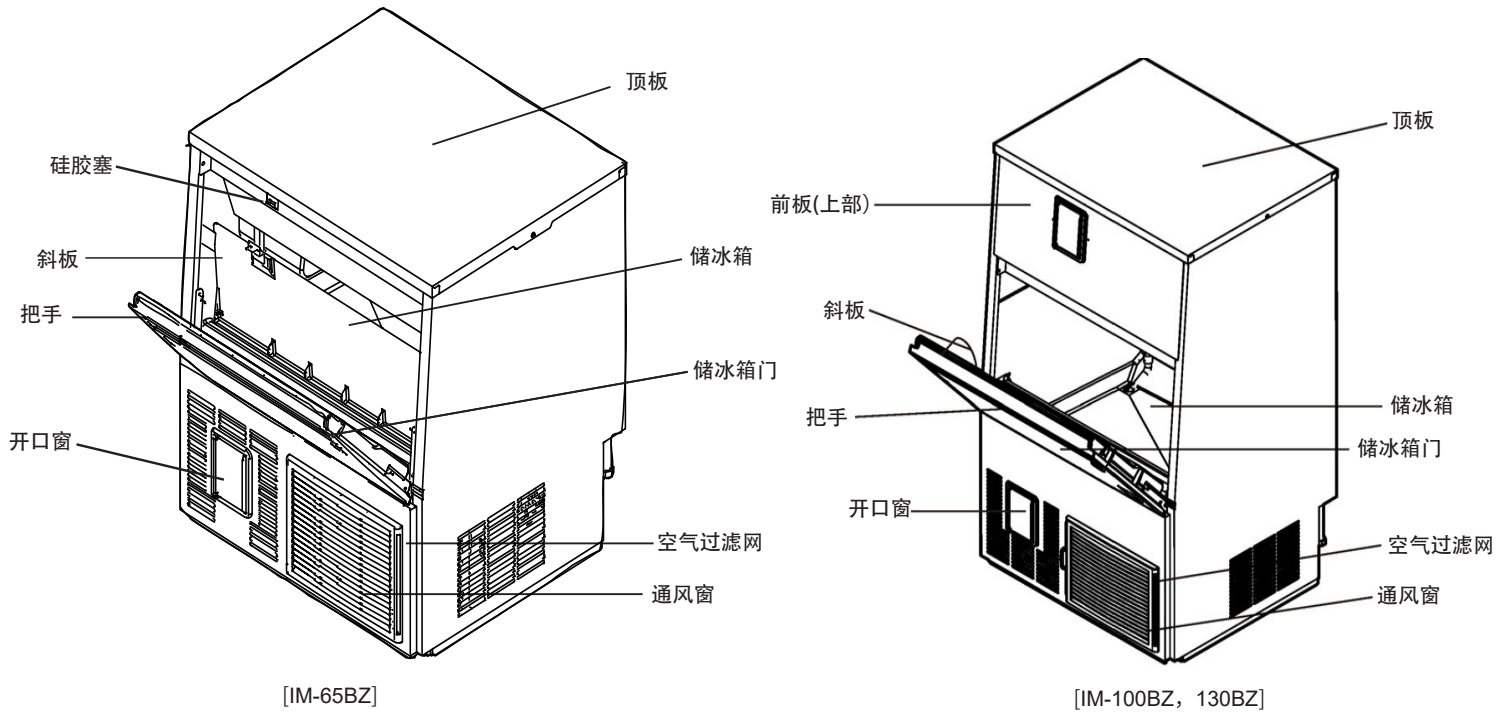

### 2. 附件

	IM-65BZ-25	IM-65BZ	IM-45CBZ	IM-45CBZ-25	IM-30CBZ	IM-30CBZ-25
使用说明书	1	1	1	1	1	1
冰铲	1	1	1	1	1	1
排水软管	1	1	1	1	1	1
支脚	4	4	4	4	4	4
漏斗	1	1	1	1	1	1

	IM-100BZ	IM-100BZ-23	IM-130BZ	IM-130BZ-23
使用说明书	1	1	1	1
冰铲	1	1	1	1
排水软管	1	1	1	1
支脚	4	4	4	4
漏斗	1	1	1	1

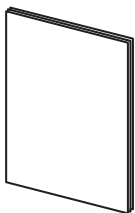

使用说明书



冰铲



排水软管



支脚

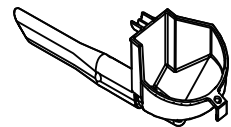

漏斗

## 3. 拆包

## ▲警告

包装零件(塑料袋和发泡聚苯乙烯等)存在潜在危险, 必须放置到儿童接触不到的地方。

## ▲小心

请勿使用搬运带提升或搬动纸箱。

手动搬动设备时, 请托起设备底部。

搬运设备时, 请戴好防护手套。

搬运纸箱或拆开包装的设备时, 请结伴作业, 以防止受伤。

## 注意

拆除运输包装纸箱、胶带和其它包装材料。如果内部遗留包装材料, 制冰机将无法正常工作。

- 1) 拆开包装后, 请确保制冰机状态良好。如有任何疑问, 请勿使用本产品, 而应与具备相应资质的专业人员联系。
- 2) 拆下用于固定制冰机门和前板的运输用胶带。
- 3) 撕掉外表面的塑料防护膜。如果制冰机暴露于阳光下或热源下, 请待制冰机冷却后再撕掉塑料防护膜。
- 4) 打开包装的附件。参照“2.附件”检查附件。
- 5) 打开储冰箱门, 撕掉固定储冰控制开关的运输用胶带。

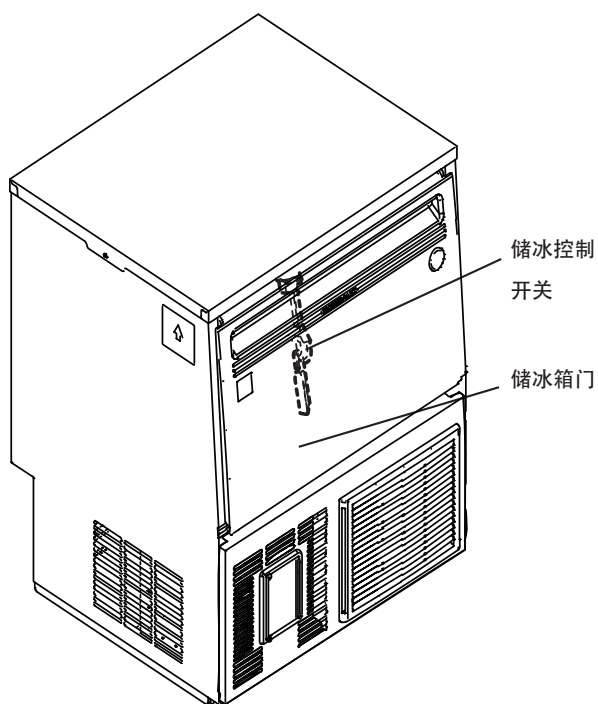

[IM-65BZ]

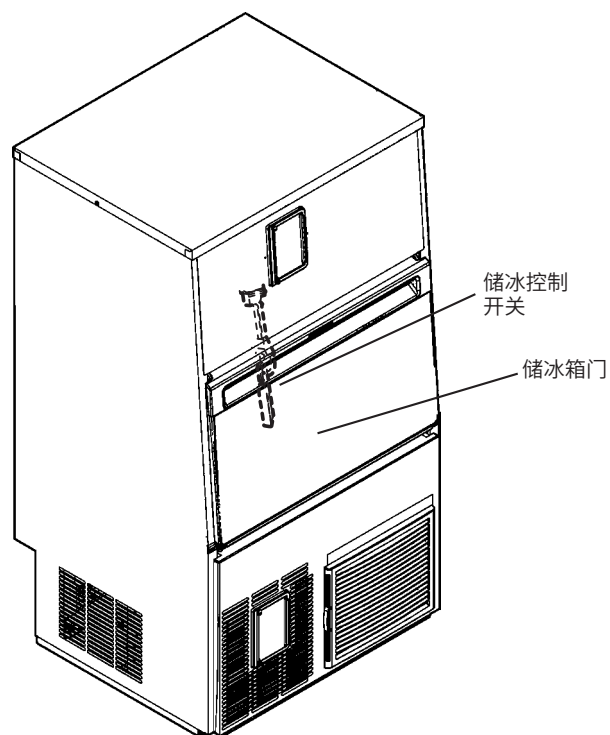

[IM-100BZ, 130BZ]

## 4. 位置

### 警告

本制冰机不适合在户外使用。

本制冰机不得安装在靠近火炉、烤箱或其它会产生高温的设备附近。

本产品不适合安装在可能使用洒水器的区域。

### 小心

制冰机应安装在坚实、平坦的地面上。

### 注意

请勿在制冰机上方或通风窗前方放置任何物品。

### 重要

正常工作环境温度应为 1°C~ 40°C，正常工作的水温应为 5°C~ 35°C。如果制冰机长时间超出上述正常温度范围工作，可能会影响制冰能力。

必须留出以下指定的空间，以确保通风顺畅和便于维修保养。

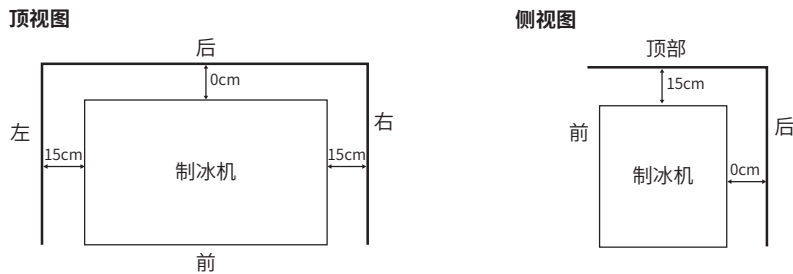

高湿度环境下，机器内部可能会产生冷凝水，从而滴在地板上。因此，请勿将其安装在易因滴水而损坏地板的场所。

## 5. 安装

### 小心

错误的安装会导致人员、动物受伤或其它物品受损，生产商对由此造成的损害不承担责任。

- \* 请将制冰机安装在固定的位置。
- \* 安装调节支脚(配件)时，将本机在左右和前后方向上调水平。

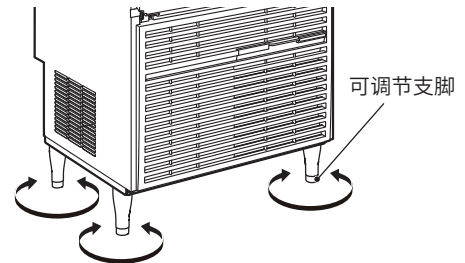

## 6. 电气连接

### 警告

#### 本制冰机必须接地

本制冰机必须按所在国家和地区的电气安全标准进行接地。

为避免造成人体触电或设备严重受损，请在制冰机上正确地连接地线。

进行任何保养、维修或清洁作业前，请切断主电源。

- \* 本制冰机需使用单独的电源(220~240VAC/10A)，且必须安装合适的断路器保护电源。
- \* 主控箱保险丝的额定电流为5A，必须交由具备相应知识的维修人员进行更换。
- \* 通常情况下，应由持有电工资质证书或经授权的维修人员进行作业。
- \* 若电源线已破损，则需更换星崎零部件/维修中心提供的电源线。

## 7. 供水和排水连接

### 警告

请仅连接至饮用水供水管。

- \* 与总供水管线的连接必须符合国家当前《供水和供水连接件规定》的相关要求。
- \* 制冰用水必须为饮用水。在易因水质问题而产生水垢的场合：
  - 建议安装一台外部过滤器或软水装置。相关事宜，敬请垂询当地的专业水处理机构或星崎维修机构。
  - 建议切换至“全排水模式”。相关事宜，敬请垂询当地的星崎维修机构。
- \* 供水水压必须在0.07MPa(0.7bar)~0.78MPa(8bar)之间。如果水压超过0.78MPa(8bar)，则须采用适当的减压阀。请勿关小供水龙头。
- \* 在部分地区可能要求具备水管敷设许可证并由持有相应资质证书的水管工进行作业。
- \* 制冰机排水靠重力流动，因此应保证排水管道具有足够的倾斜度或落差。

\* 不得将排水管路直接连接至下水道系统。制冰机的排水管末端与地面排水之间至少需留出5cm的垂直间隙。

\* 排水软管必须按图所示敷设，以避免水回流至储冰箱内部。

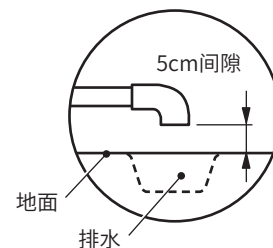
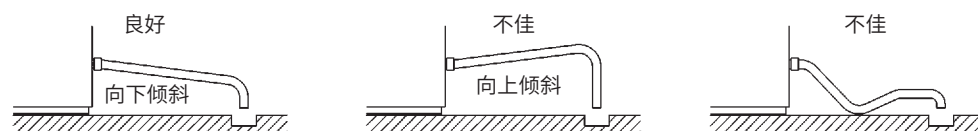

\* 请务必使用本机附带的全新软管套件。请勿使用老旧的软管套件。

- 1) 将进水软管的另一端与截止阀(供水龙头)连接，固定前请确认垫圈已正确就位。手动充分拧紧垫圈，以防止接头漏水。最好在易于触及的部位安装一个截止阀。
- 2) 如图所示，将灰色挠性排水软管(附件)手动紧固到制冰机后方的管接头上。可根据主排水口的位置将排水管剪切到合适的长度。为防止漏水，请使用软管卡箍将排水软管固定到排水口处。

注：水管连接必须经过有关部门批准并符合饮用水标准。

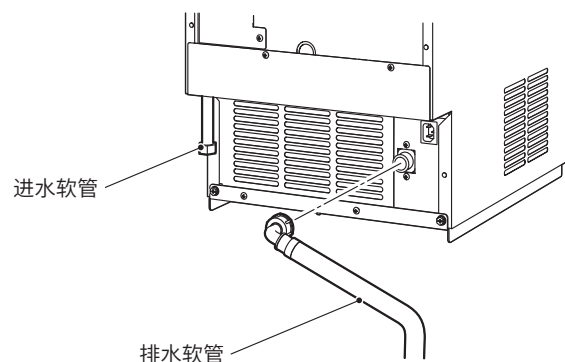
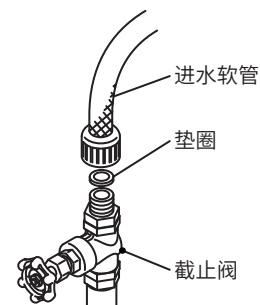

## II. 操作说明

### ⚠小心

请勿将手伸进储冰箱背面或顶部的冰槽中，制冰机上部的冰块可能掉落、大块硬质冰可能突然碎裂或制冰机构可能突然启动，从而引发伤害事故。

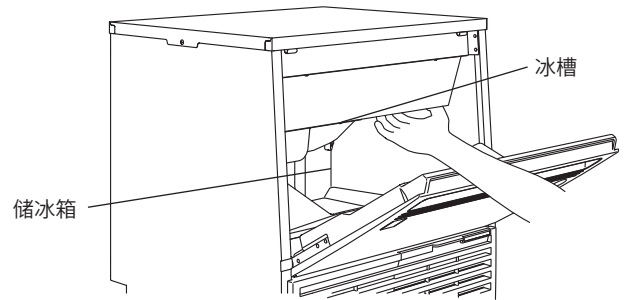

请勿悬吊或踩踏在机门上或在机门放置重物，否则可能会导致机门掉落或机器倾翻，进而导致人员受伤。

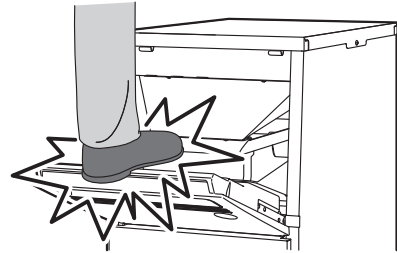

### 注意

所有零部件在出厂前均经过调整。调整不当可能会导致故障。

关闭制冰机后，应至少等待3分钟后再重新启动制冰机，以防止压缩机受损。

### ⚠卫生

本制冰机设计用于制造食用冰。为保持制冰机清洁卫生，应做到以下几点：

- \* 取冰前先洗手。使用附带的塑料冰铲(附件)取冰。
- \* 储冰箱仅用于储存冰块。请勿在储冰箱内存储其它物品，或在储冰箱内使用其它电器。
- \* 使用前须清洁储冰箱(参见“III. 1. 清洁”)。
- \* 保持冰铲清洁。用中性清洁剂清洗后再用水彻底冲洗。
- \* 取冰后关闭储冰箱门，以防止污垢、灰尘或昆虫进入储冰箱。

## 1. 启动

安装人员通常会试运行制冰机，启动自动制冰过程。为确保制冰机可以连续工作，请确认以下内容：

- \* 供水龙头已经打开；
- \* 制冰机已经接通电源。

## 2. 长时间不使用制冰机时

### 注意

本制冰机无法在冰点以下温度工作。为防止损坏供水管路，当气温低于零度时，请排空制冰机内的水。

### ⚠卫生

制冰机停机2天或2天以上时，请将里面的水排空，以防止水路污染。

- 1) 拔下制冰机插头或断开电源。
- 2) 关闭供水龙头，然后拆下进水软管。
- 3) 取出储冰箱内所有冰块并清洁储冰箱。
- 4) 请具备相应知识的专业人员对制冰机执行排水作业。

### III. 保养

#### 1. 清洁

##### ▲警告

进行清洁或保养作业前，请将制冰机的电源插头从供电网络上拔下。

严禁用喷水器冲洗本制冰机。

##### ▲小心

使用中性溶液或次氯酸钠溶液时，请务必充分阅读并理解所附带的说明，防止产生潜在的健康问题。

##### 注意

应由受过培训的维修人员对制冰机水路系统进行清洁和消毒作业(每年至少两次)，并对冷凝器进行检查和清洁作业(每年至少一次)。

请勿将塑料零件放入温度超过 40°C 的水中或洗碗机中清洗，以免损坏零件。

#### [a] 制冰机和储冰箱外壳

用干净的软布每周至少擦拭制冰机的外壳一次。用含有中性清洁剂的湿布擦拭油脂或脏物。

#### [b] 冰铲的清洗和消毒(每天)

- 1) 按指示要求在合适的容器中倒入1升水，然后加入4毫升浓度为5.25%次氯酸钠溶液或者星崎推荐的消毒剂进行混合。
- 2) 将冰铲浸泡在溶液中3分钟以上，然后彻底冲洗并用干多余的水分。

注：用抹布擦干可能会导致二次污染。

#### [c] 储冰箱内部的清洗和消毒(每周)

- 1) 打开储冰箱门，取出所有冰块。
- 2) 使用中性不含细小微粒的清洁剂清洗储冰箱内胆，然后彻底冲洗干净。
- 3) 用在中性清洁剂中浸泡过的干净抹布擦拭斜板两面和储冰箱门的内侧表面。用一块干净的湿抹布将清洁剂擦拭干净。
- 4) 按指示要求在合适的容器中倒入5升水，然后加入18毫升浓度为5.25%次氯酸钠溶液或者星崎推荐的消毒剂进行混合。
- 5) 用在溶液中浸泡过的干净海绵或抹布擦拭储冰箱内胆、储冰箱门和斜板。
- 6) 剩下的清洁液可用于清洁器皿。

注：请勿在消毒后立即擦干或冲洗器皿，仅可采用风干处理。

#### [d] 空气过滤网

塑料网状空气过滤网可以滤除空气中的污垢或灰尘，防止冷凝器堵塞。如果过滤网堵塞，制冰机的性能将会下降。每月请拆下并清洗空气过滤网至少两次：

- 1) 将空气过滤网从过滤网导槽[适用于IM-30CBZ机型]或通风窗[适用于IM-45CBZ/65BZ/100BZ/130BZ机型]上滑下。
- 2) 请使用真空吸尘器清洁空气过滤网。如果空气过滤网严重堵塞，请用温水和中性清洁剂清洗。
- 3) 彻底冲洗并晾干空气过滤网。

## [e] 制冰机水路系统

## 自动药剂洗净

通过手动供给药剂，有效清洁水路。

## ▲小心

使用柠檬酸或次氯酸钠溶液时，请穿戴防护设备(如护目镜)。否则，溶液可能会喷出并溅入眼睛。如出现以上情况，用清水冲洗眼睛。

## 注意

如果柠檬酸溶液滴在钣金部件上，请将其彻底擦除，以防止生锈。

1) 调配以下任一溶液以实现预期目标。

除垢剂：柠檬酸浓度 60 - 100%

将 56.7g x 1 袋添加到 3 升的室温水中

消毒剂：有效氯浓度 3 - 3.8%

将 28.4g x 1 袋添加到 6 升的室温水中

2) 打开储冰箱门，从储冰箱中取出所有冰块。

3) 长按【维修2键】(3秒钟)，显示屏显示"Pr"，进入洗净模式。  
当显示"□"时，投放药液。

4) 拔开硅胶塞，将漏斗插入导槽内。

IM-30CBZ: 0.79 L

IM-30CBZ-25: 0.79 L

IM-45CBZ: 1.24 L

IM-45CBZ-25: 1.24 L

IM-65BZ: 1.5 L

IM-65BZ-25: 1.5 L

IM-100BZ: 2.7L

IM-100BZ-23: 2.7 L

IM-130BZ: 2.7L

IM-130BZ-23: 2.7 L

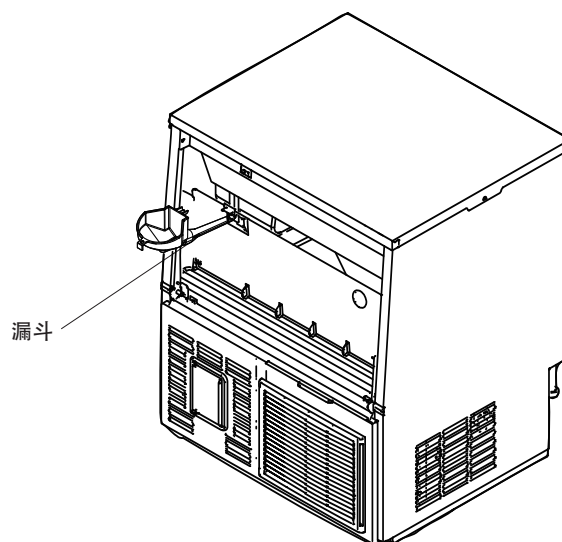

注:使用前，请对漏斗进行清洁和消毒。

5) 向漏斗口加入适量的药液(根据不同机型加入适量药液)，投入药液指示出现后，15min内将药液通过漏斗加入。

6) 投入药液后短按【维修2】键(1秒钟)，制冰机将立即清洗，显示屏将显示""  
，或者投入药液指示出现15min后，制冰机也可自动开始清洗。

7) 盖上硅胶塞，关闭储冰箱门。

8) 制冰机将自动进行清洗，漂洗过程，全程大约需要80min。

9) 整个洗净步骤结束后，制冰机将自动切换至正常制冰模式。

## ▲警告

如果在自动药剂洗净后制成的冰块变味，请立即停止使用制冰机并联系维修机构。

## 注意

清洁后，请务必将空气过滤网装回原处。

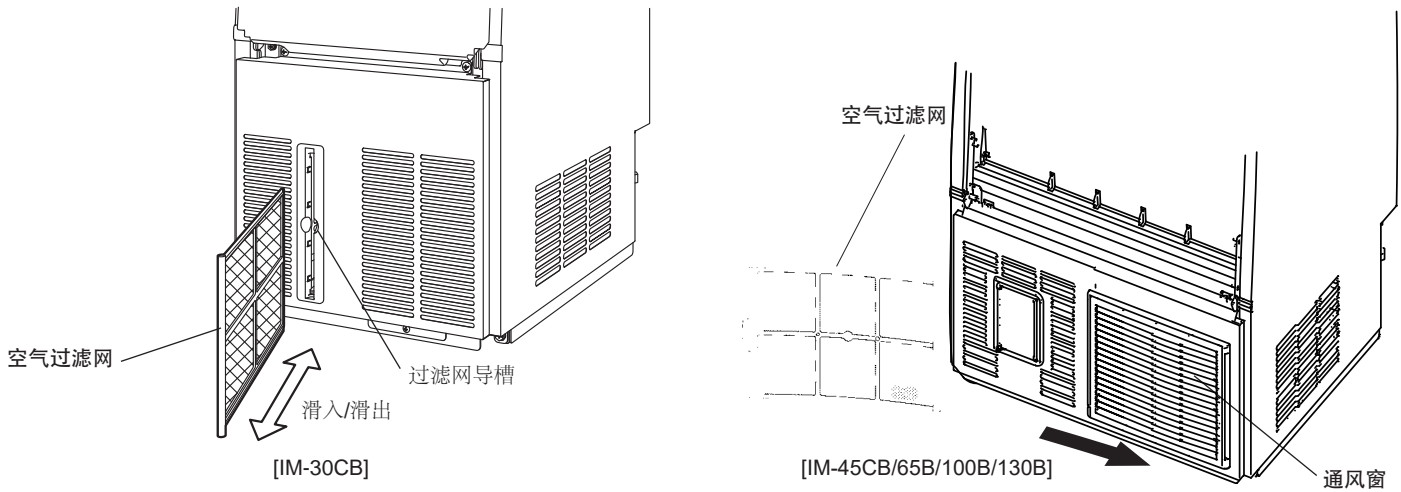

## 2. 联系维修机构前

### 警告

请勿损坏制冷剂回路。

如果制冰机无法正常工作或根本不工作且显示屏上无故障代码显示，请在联系维修机构前检查以下事项：

- \*制冰机的电源是否接通。
- \*水龙头是否打开。
- \*空气过滤网是否干净。

请联系当地的星崎维修机构，以获取进一步的帮助或咨询。

## 3. 废弃处理

对本制冰机及其附带的制冷剂气体进行废弃处理时，请遵照当地的法律法规。在丢弃本产品前，请务必拆下柜门，以防儿童不慎进入。

## 重要



用于机体的隔热材料发泡剂含有易燃气体环戊烷。请记住这一点，正确处置本产品。

## 4. 保修

星崎原始向拥有者/用户保证，星崎品牌的所有产品在产品“保修期”内不存在材料和/或工艺缺陷。产品保修在自产品安装之日起两年内有效。

星崎在此保修条款下承担有限责任，日常维护、清洁、必需的保养和/或因误用以及未根据星崎的准则安装而导致的修理则不在星崎的责任范围内。

保修范围内的维修应由授权的星崎经销商或维修机构采用星崎的原装/纯正零部件实施。

若要获取有关保修和授权维修机构的详细信息，请联系经销商/供货商或最近的星崎维修办事处。

## 规格

型号	IM-65BZ-25	IM-65BZ	IM-45CBZ
类型	风冷型, 方形冰	风冷型, 方形冰	风冷型, 方形冰
电源	单相220~240V 50Hz	单相220~240V 50Hz	单相220~240V 50Hz
功率	390W	390W	310W
每24小时的制冰量	58kg(5mm)/59kg(15mm)(环境温度10°C, 水温10°C)	65kg(5mm)/70kg(15mm)(环境温度10°C, 水温10°C)	45kg(5mm)/47kg(15mm)(环境温度10°C, 水温10°C)
尺寸	660mm(宽)×589mm(深)×800mm(高)	660mm(宽)×570mm(深)×800mm(高)	660mm(宽)×570mm(深)×695mm(高)
制冷剂	R134a, 260g	R134a, 260g	R134a, 160g
重量	净重: 60kg(毛重: 74kg)	净重: 60kg(毛重: 74kg)	净重: 52kg(毛重: 65kg)
环境温度	1~40°C	1~40°C	1~40°C
供水温度	5~35°C	5~35°C	5~35°C
供水压力	0.07~0.78MPa(0.7~8bar)	0.07~0.78MPa(0.7~8bar)	0.07~0.78MPa(0.7~8bar)
电压范围	额定电压±6%	额定电压±6%	额定电压±6%

型号	IM-45CBZ-25	IM-30CBZ	IM-30CBZ-25
类型	风冷型, 方形冰	风冷型, 方形冰	风冷型, 方形冰
电源	单相220~240V 50Hz	单相220~240V 50Hz	单相220~240V 50Hz
功率	310W	250W	250W
每24小时的制冰量	41kg(5mm)/48kg(15mm)(环境温度10°C, 水温10°C)	27kg(5mm)/30kg(15mm)(环境温度10°C, 水温10°C)	25kg(5mm)/30kg(15mm)(环境温度10°C, 水温10°C)
尺寸	660mm(宽)×570mm(深)×695mm(高)	398mm(宽)×510mm(深)×695mm(高)	398mm(宽)×510mm(深)×695mm(高)
制冷剂	R134a, 160g	R134a, 130g	R134a, 130g
重量	净重: 52kg(毛重: 65kg)	净重: 39kg(毛重: 49kg)	净重: 39kg(毛重: 49kg)
环境温度	1~40°C	1~40°C	1~40°C
供水温度	5~35°C	5~35°C	5~35°C
供水压力	0.07~0.78MPa(0.7~8bar)	0.07~0.78MPa(0.7~8bar)	0.07~0.78MPa(0.7~8bar)
电压范围	额定电压±6%	额定电压±6%	额定电压±6%

型号	IM-100BZ	IM-130BZ	IM-100BZ-23
类型	风冷型, 方形冰	风冷型, 方形冰	风冷型, 方形冰
电源	单相220~240V 50Hz	单相220~240V 50Hz	单相220~240V 50Hz
功率	680W	630W	680W
每24小时的制冰量	100kg(5mm)/112kg(15mm)(环境温度10°C, 水温10°C)	120kg(5mm)/126kg(15mm)(环境温度10°C, 水温10°C)	90kg(5mm)/96kg(15mm)(环境温度10°C, 水温10°C)
尺寸	660mm(宽)×570mm(深)×1200mm(高)	660mm(宽)×570mm(深)×1200mm(高)	660mm(宽)×570mm(深)×1200mm(高)
制冷剂	R404a, 400g	R404a, 350g	R404a, 400g
重量	净重: 76kg(毛重: 95kg)	净重: 79kg(毛重: 98kg)	净重: 76kg(毛重: 95kg)
环境温度	1~40°C	1~40°C	1~40°C
供水温度	5~35°C	5~35°C	5~35°C
供水压力	0.07~0.78MPa(0.7~8bar)	0.07~0.78MPa(0.7~8bar)	0.07~0.78MPa(0.7~8bar)
电压范围	额定电压±6%	额定电压±6%	额定电压±6%

注: 上述规格适用于代表型号。

制品标准番号:  
GB 4706.1  
GB 4706.13

## 规格

型号	IM-130BZ-23
类型	风冷型, 方形冰
电源	单相220~240V 50Hz
功率	660W
每24小时的制冰量	100kg(5mm)/106kg(15mm) (环境温度10°C, 水温10°C)
尺寸	660mm(宽)×570mm(深)× 1200mm(高)
制冷剂	R404a, 450g
重量	净重: 79kg(毛重: 98kg)
环境温度	1~40°C
供水温度	5~35°C
供水压力	0.07~0.78MPa(0.7~8bar)
电压范围	额定电压±6%

注: 上述规格适用于代表型号。

制品标准番号:  
GB 4706.1  
GB 4706.13

# 安全注意事项

## 1. 电器电子产品中有害物质含有信息表

产品中有害物质的名称及含有的信息表											
部件名称	对象机种(型号)	有害物质									
		铅	汞	镉	六价铬	多溴联苯	多溴二苯醚	邻苯二甲酸二正丁酯	邻苯二甲酸二异丁酯	邻苯二甲酸丁苄酯	邻苯二甲酸二(2-乙基)己酯
		(Pb)	(Hg)	(Cd)	(Cr(VI))	(PBBs)	(PBDEs)	(DBP)	(DIBP)	(BBP)	(DEHP)
开关适配器	冰箱, 肉锅	×	○	○	○	○	○	○	○	○	○
基板	肉锅, 制冰机, 冰箱	×	○	○	○	○	○	○	○	○	○
基板线束	肉锅	×	○	○	○	○	○	○	○	○	○
电源继电器	制冰机, 冰箱	×	○	○	○	○	○	○	○	○	○
水冷冷凝器	制冰机	×	○	○	○	○	○	○	○	○	○
冷凝器	冰箱	×	○	○	○	○	○	○	○	○	○
压缩机	制冰机, 冰箱	×	○	×	○	○	○	○	○	○	○
变频器	冰箱	×	○	○	○	○	○	○	○	○	○
电源线	啤酒机, 制冰机, 冰箱	×	○	○	○	○	○	○	○	○	○
拨动开关	制冰机	×	○	○	○	○	○	○	○	○	○
风扇马达	冰箱, 肉锅	×	○	○	○	○	○	○	○	○	○
把手	肉锅	×	○	○	○	○	○	○	○	○	○
填充阀	冰箱, 制冰机, 啤酒机	×	○	○	○	○	○	○	○	○	○
膨胀阀	制冰机	×	○	○	○	○	○	○	○	○	○
热敏电阻	制冰机	×	○	○	○	○	○	○	○	○	○
螺母	制冰机	×	○	○	○	○	○	○	○	○	○
水量调节阀	制冰机	×	○	○	○	○	○	○	○	○	○

○: 表示该有害物质在该部件所有均质材料中的含量均不超出电器电子产品有害物质限制使用国家标准要求。

×: 表示该有害物质至少在该部件的某一均质材料中含量超出电器电子产品有害物质限制使用国家标准要求。

注1: 以上未列出的部件, 表明其有害物质含量均不超出电器电子产品有害物质限制使用国家标准要求。

注2: 本产品的部件均采用无毒无害的绿色环保材料制造, 所含有的非环保类物质或元素皆由于全球的技术和工艺水平限制而无法实现非环保类物质或元素的完全替代, 但本产品中非环保类物质或元素的含量极其微小, 长期使用不会对人体产生危害, 请放心使用。

## 2. 环保标识的说明:



本产品根据国家法规《电器电子产品有害物质限制使用管理办法》的相关规定, 采用了国家标准《GB26572-2025 电器电子产品有害物质限制使用要求》中电子电器产品有害物质控制标志。

## 3. 废弃电子电器产品回收处理说明:

为了更好地关爱及保护地球, 当用户不再需要此产品或产品寿命终止时, 请遵守国家废弃电子电器产品回收处理相关法律法规, 将其交给当地具有国家认可的回收处理资质的厂商进行回收处理。



# ENGLISH

## IMPORTANT SAFETY INFORMATION

Throughout this manual, notices appear to bring your attention to situations which could result in death, serious injury, or damage to the unit.

<b>▲WARNING</b>	Indicates a hazardous situation which, if not avoided, could result in death or serious injury.
<b>▲CAUTION</b>	Indicates a hazardous situation which, if not avoided, could result in minor or moderate injury.
<b>NOTICE</b>	Indicates a hazardous situation which, if not avoided, could result in damage to the unit.
<b>▲HYGIENE</b>	Indicates important precautions for hygiene and food safety.
<b>IMPORTANT</b>	Indicates important information about the use and care of the unit.

<b>▲WARNING</b>	
<p>This is a commercial icemaker, and should be destined only to be used for the purpose for which it has been expressly designed. Any other use should be considered improper and therefore dangerous. The manufacturer will not be held liable or responsible for any damage caused by improper, incorrect and unreasonable use.</p>	
<p><b>The installation, and relocation if necessary, must be carried out by qualified personnel</b>, in accordance with current regulations, according to the manufacturer's instructions.</p>	
<p>Keep ventilation openings, in the appliance enclosure or in the built-in structure, clear of obstruction.</p>	
<p>The use of any electrical appliance involves the observance of some fundamental rules. In particular:</p> <ul style="list-style-type: none"><li>* Instances of high humidity and moisture increase the risk of electrical short circuits and potential electrical shocks. If in doubt, disconnect the icemaker.</li><li>* Do not damage the power cord or pull it in order to disconnect the icemaker from the electrical supply network.</li><li>* Do not touch the electrical parts or operate the switches with damp hands.</li><li>* This appliance is not intended for use by persons (including children) with reduced physical, sensory or mental capabilities, or lack of experience and knowledge, unless they have been given supervision or instruction concerning use of the appliance by a person responsible for their safety.</li><li>* Young children should be supervised to ensure that they do not play with the appliance.</li><li>* Do not attempt to modify the icemaker. Only qualified personnel may disassemble or repair the appliance.</li></ul>	

## I. INSTALLATION INSTRUCTIONS

### 1. CONSTRUCTION

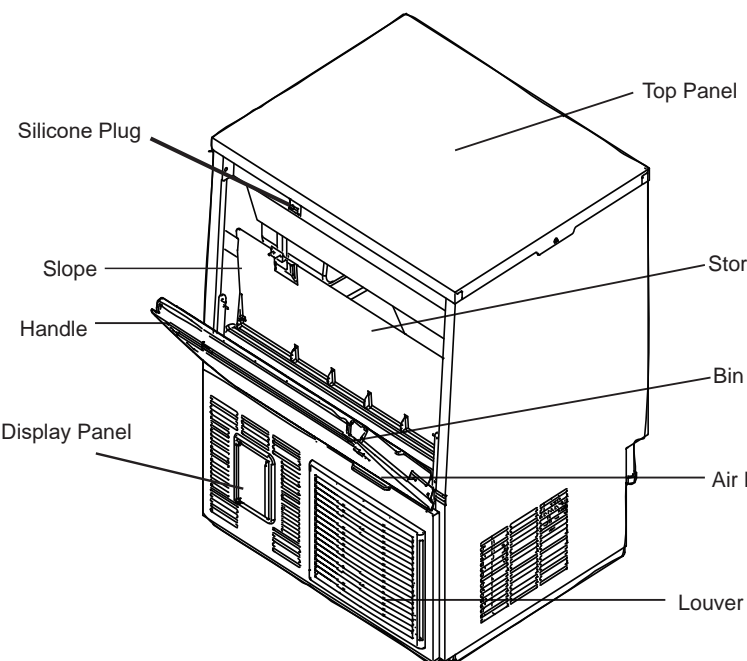

[IM-65BZ]

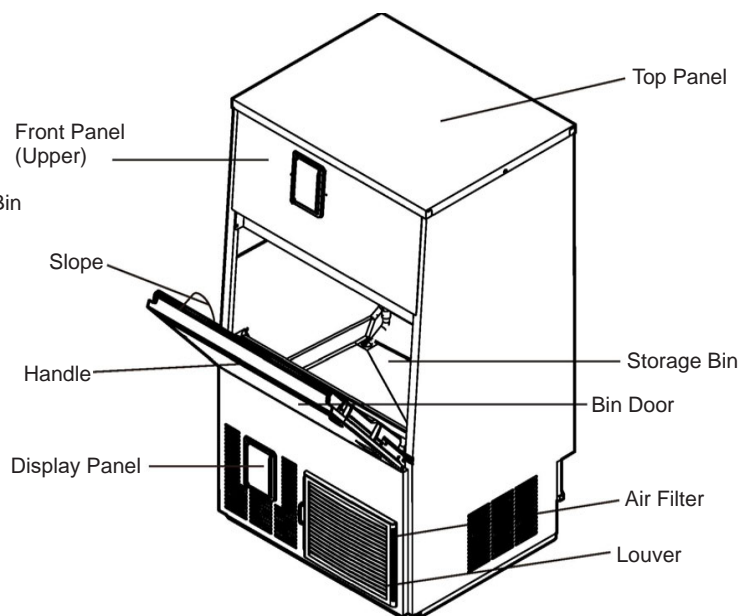

[IM-100BZ, 130BZ]

### 2. ACCESSORIES

	IM-65BZ-25	IM-65BZ	IM-45CBZ	IM-45CBZ-25	IM-30CBZ	IM-30CBZ-25
Instruction Manual	1	1	1	1	1	1
Scoop	1	1	1	1	1	1
Outlet Hose	1	1	1	1	1	1
Leg	4	4	4	4	4	4
Funnel	1	1	1	1	1	1

	IM-100BZ	IM-100BZ-23	IM-130BZ	IM-130BZ-23
Instruction Manual	1	1	1	1
Scoop	1	1	1	1
Outlet Hose	1	1	1	1
Leg	4	4	4	4
Funnel	1	1	1	1

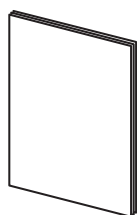

Instruction Manual



Scoop



Outlet Hose



Leg

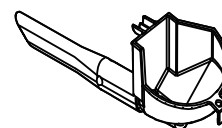

Funnel

# ENGLISH

## 3. UNPACKING

### ⚠ WARNING

Children should not be allowed in reach of the packaging elements (plastic bags and expanded polystyrene) as they are potential sources of danger.

### ⚠ CAUTION

Do not lift or manoeuvre the carton by using the shipping bands.

When moving the unit by hand, hold the unit bottom.

Always wear protective gloves when carrying the unit.

When handling the carton or the unpacked unit, work in pair to prevent injury.

### NOTICE

Remove shipping carton, tape(s) and packing. If packing material is left in the icemaker, it will not work properly.

- 1) After removing the packaging, make sure that the icemaker is in good condition. If in doubt, please do not use the icemaker but apply to professionally qualified personnel.
- 2) Remove the shipping tape holding the door and front panel.
- 3) Remove the protective plastic film from the exterior. If the icemaker is exposed to the sun or to heat, remove the film after the icemaker cools.
- 4) Remove the package of accessories. Check the contents according to "2. ACCESSORIES".
- 5) Remove the shipping tape holding the bin control switch by opening the bin door and reaching in.

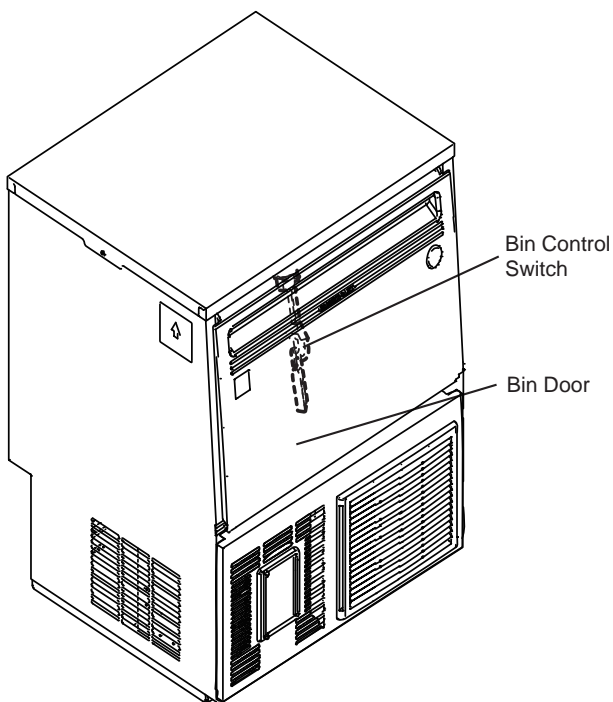

[IM-65BZ]

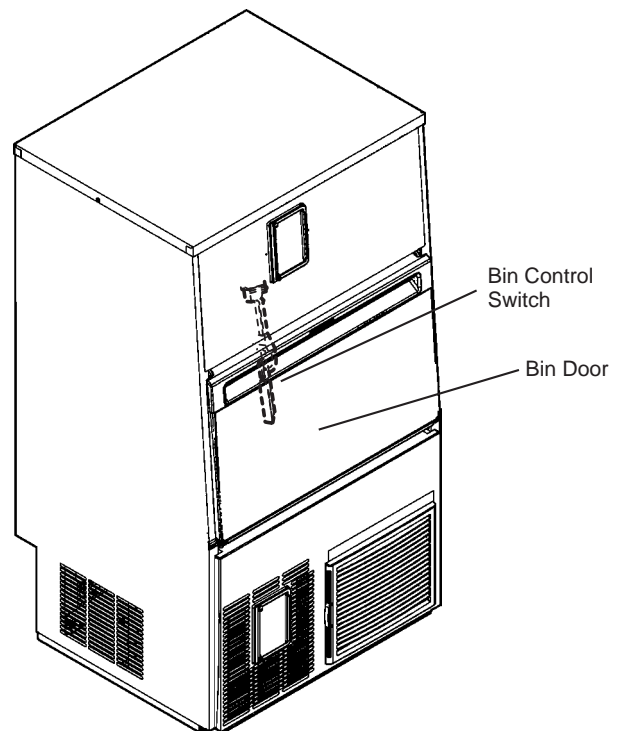

[IM-100BZ, 130BZ]

## 4. LOCATION

### ⚠ WARNING

This icemaker is not intended for outdoor use.

The icemaker should not be located next to ovens, grills or other high heat producing equipment.

This appliance is not suitable for installation in an area where a water jet could be used.

### ⚠ CAUTION

The location should provide a firm and level foundation for the icemaker.

### NOTICE

Do not place anything on top of the icemaker or in front of the louver.

### IMPORTANT

Normal operating ambient temperature should be within 1°C to 40°C. Normal operating water temperature should be within 5°C to 35°C. Operation of the icemaker, for extended periods, outside of these normal temperature ranges may affect production capacity.

Allow the clearance specified below for proper air circulation and ease of maintenance and/or service should they be required.

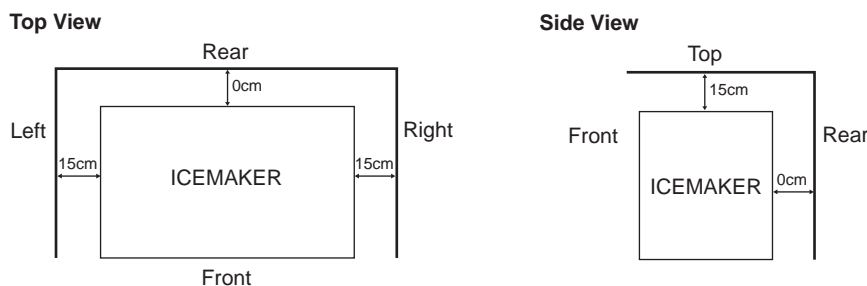

In some high humidity environments, condensation may form inside the machine and drip onto the floor. Do not install where the floor can be affected by water.

## 5. INSTALLATION

### ⚠ CAUTION

Incorrect installation can cause harm to people, animals or other items, for which the manufacturer cannot be held responsible.

- \* Place the icemaker in the selected permanent site.
- \* When attaching the adjustable legs (accessory), level the unit in both the left-to-right and front-to-rear directions.

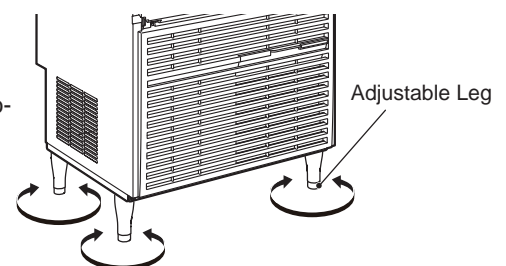

## 6. ELECTRICAL CONNECTIONS

### ⚠ WARNING

#### THIS APPLIANCE MUST BE EARTHED

This icemaker requires an earth that meets the national and local electrical code requirements.

To prevent possible severe electrical shock to individuals or extensive damage to the unit, install a proper earth wire to the icemaker.

Disconnect the main power supply before any maintenance, repairs or cleaning is undertaken.

- \* This appliance requires a separate 220 - 240VAC, 10A supply. The electrical supply must be protected by a suitable circuit breaker.

- \* The main control box fuse is rated at 5A and should only be replaced by a qualified service engineer.

# ENGLISH

\* Usually an electrical permit and services of a licensed electrician are required.

\* If the supply cord is damaged, it must be replaced by a replacement cord available from Hoshizaki Parts/Service Centres.

## 7. WATER SUPPLY AND DRAIN CONNECTIONS

### ⚠ WARNING

Connect to potable water supply only.

\* The connections to the mains water supply must be made in accordance with the countries' current requirements of the Water Supply or Water Fittings Regulations.

\* Icemaking water must be potable water. Where scaling can be caused by water quality:

- Installation of an external filter or softener is recommended. Contact your local water treatment professional or Hoshizaki service agent.
- Change to the "full drain flush" mode is recommended. Contact your local Hoshizaki service agent.

\* Water supply pressure should be minimum 0.07 MPa (0.7 bar) and maximum 0.78 MPa (8 bar). If the pressure exceeds 0.78 MPa (8 bar), use a proper pressure reducing valve. Do NOT throttle back the supply tap.

\* A plumbing permit and services of a licensed plumber may be required in some areas.

\* The icemaker drain is gravity flow, so ensure drain pipe has an adequate pitch or fall.

\* Drain lines should not be piped directly to the sewer system. A vertical air gap of a minimum of 5 cm should be between the end of the drain pipes from the icemaker and the floor drain.

\* To prevent a backflow into the storage bin, the outlet hose must be laid as shown.

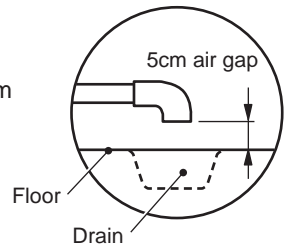
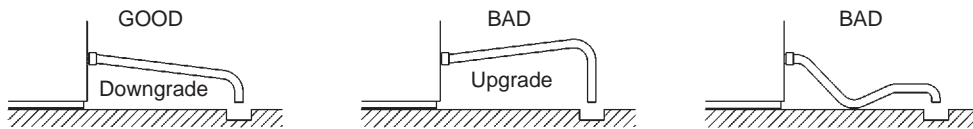

\* Be sure to use the new hose-sets supplied with the appliance. Do not reuse any old hose-sets.

1) Attach the free end of inlet hose to the stop valve, noting washer is correctly positioned. Hand tighten sufficiently to provide leak free joint. It is a wise precaution to have the stop valve within easy reach.

2) Connect grey flexible outlet hose (accessory) to the fitting on the rear of the icemaker as indicated. The pipe can be cut to length as necessary to suit position of main drain. To prevent water leaks, secure the outlet hose to the drain outlet by using a hose band.

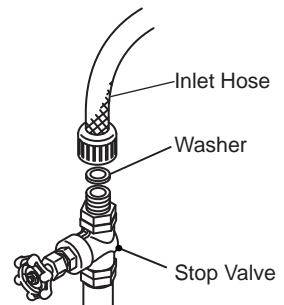

Note: Jointing compounds should be approved and suitable for potable water use.

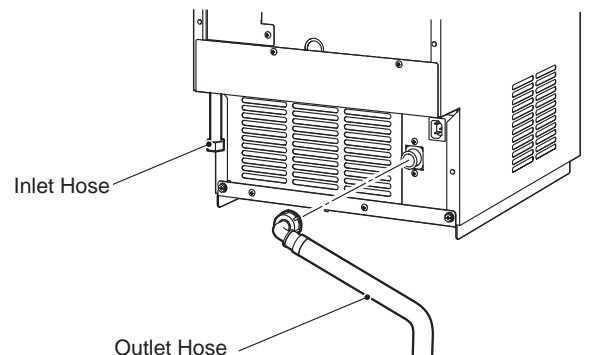

## II. OPERATING INSTRUCTIONS

### ⚠ CAUTION

Do not put your hands into the back of the storage bin or the ice chute on top of the storage bin. Ice may drop off the icemaker, a hard block of ice may suddenly break down, or the icemaking mechanism may suddenly move, resulting in injury.

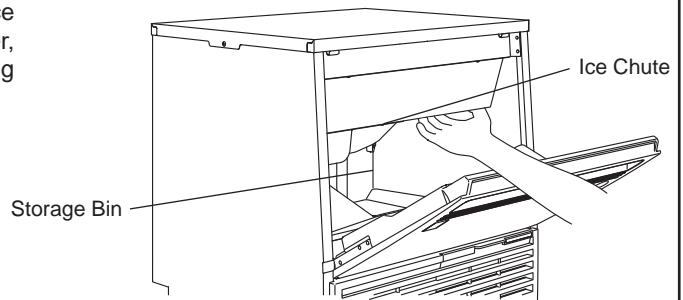

Do not hang or step on the door or put any object. The door may drop off, or the unit may fall, resulting in injury.

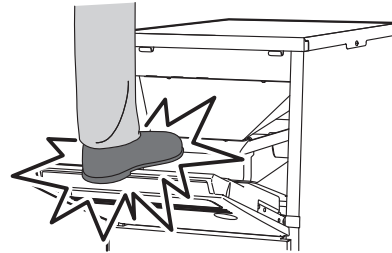

### NOTICE

All parts are factory-adjusted. Improper adjustments may result in failure.

If the unit is turned off, wait for at least 3 minutes before restarting the icemaker to prevent damage to the compressor.

### ⚠ HYGIENE

This icemaker is designed to produce edible ice. To keep the icemaker hygienic:

- \* Wash your hands before removing ice. Use the plastic scoop provided (accessory).
- \* The storage bin is for ice use only. Do not store anything else in the bin nor use other electrical appliances in the bin.
- \* Clean the storage bin before use (see "III. 1. CLEANING").
- \* Keep the scoop clean. Clean it by using a neutral cleaner and rinse thoroughly.
- \* Close the door after removing ice to prevent entrance of dirt, dust or insects into the storage bin.

## 1. START UP

The installer will normally commission the icemaker to start the automatic icemaking process. To ensure continuous operation, make sure that:

- \* The water supply tap is on, and
- \* The icemaker is connected to the power supply.

## 2. PREPARING THE ICEMAKER FOR LONG STORAGE

### NOTICE

This icemaker will not work at subfreezing temperatures. To prevent damage to the water supply line, drain the icemaker when air temperature is below zero.

### ⚠ HYGIENE

When shutting down the icemaker for two or more days, drain the icemaker to prevent contamination in the water circuit.

- 1) Unplug the icemaker or disconnect the power supply.
- 2) Close the water supply tap, and remove the inlet hose.
- 3) Remove all ice from the storage bin, and clean the bin.
- 4) Ask for draining of the icemaker by professional qualified personnel.

## III. MAINTENANCE

### 1. CLEANING

#### ⚠ WARNING

Before carrying out any cleaning or maintenance operations, unplug the icemaker from the electrical supply network.

This appliance must not be cleaned by use of a water jet.

#### ⚠ CAUTION

When using a neutral cleaner or sodium hypochlorite, thoroughly read and understand the instructions provided to prevent potential health problems.

#### NOTICE

Ask a trained service person to clean and sanitise the icemaker water system at least twice a year and to check and clean the condenser at least once a year.

To prevent possible damage, do not clean the plastic parts with water above 40°C or in a dishwasher.

#### [a] Machine and Bin Exterior

Wipe the exterior at least once per week with a clean, soft cloth. Use a damp cloth containing a neutral cleaner to wipe off grease or dirt.

#### [b] Scoop Cleaning/Sanitisation (Daily)

1) Either mix 1 litre of water with 4 ml of 5.25% sodium hypochlorite solution in a suitable container, or the recommended Hoshizaki sanitiser as directed.

2) Soak the scoop in the solution for more than 3 minutes. Rinse thoroughly, and shake to remove surplus liquid.

Note: Using a cloth to dry may re-contaminate.

#### [c] Storage Bin Interior Cleaning/Sanitisation (Weekly)

1) Open the storage bin door, and remove all ice.

2) Wash the bin liner with a neutral non-abrasive cleaner. Rinse thoroughly.

3) Soak a clean cloth with the neutral cleaner, and wipe both sides of the slope and the door inner surface. Wipe off the cleaner with a clean damp cloth.

4) Either mix 5 litres of water with 18 ml of 5.25% sodium hypochlorite solution in a suitable container, or the recommended Hoshizaki sanitiser as directed.

5) Soak a clean sponge or cloth with the solution, and wipe the bin liner, bin door and slope.

6) The remaining solution can be used to sanitise utensils.

Note: Do not wipe dry or rinse after sanitising, but allow to air dry.

#### [d] Air Filter

Plastic mesh air filters remove dirt or dust from the air, and keep the condenser from getting clogged. If the filters get clogged, the icemaker's performance will be reduced. Remove and clean the air filter(s) at least twice per month:

1) Slide the air filter off the filter guide [IM-30CA] or the louver [IM-45CA/65A/100A/130A].

2) Clean the air filter by using a vacuum cleaner. When severely clogged, use warm water and a neutral cleaner to wash the air filter.

3) Rinse and dry the air filter thoroughly.

# ENGLISH

## [e] Icemaking Water System

### **Automated Chemical Cleaning**

Effectively clean the water circuit by manually feeding a chemical.

#### **⚠ CAUTION**

Wear protective equipment (e.g. protective glasses) when using the citric acid or sodium hypochlorite solution. The solution may spout out and splash into your eyes. In that case, wash your eyes with clean water.

#### **NOTICE**

If the citric acid solution is found dripping on the sheet metal parts, wipe it off thoroughly to prevent rust.

1) Make either of the following solutions to fit the intended purpose.

Cleaning : Citric acid concentration range 60~100%

Add 56.7g x 1 bags to 3 liters of room temperature water

Sanitising : Available chlorine concentration range 3~3.8%

Add 28.4g x 1 bag to 6 liters of room temperature water

2) Open the freezer door and remove all ice cubes from the freezer.

3) Long press [Maintenance 2 button] (3 seconds), the display display "Pr", enter the cleaning mode. When "□" is displayed, administer the liquid medicine.

4) Remove the silicone plug and insert the funnel into the guide groove.

IM-30CBZ: 0.79 litres

IM-30CBZ-25: 0.79 litres

IM-45CBZ: 1.24 litres

IM-45CBZ-25: 1.24 litres

IM-65BZ: 1.5 litres

IM-65BZ-25: 1.5 litres

IM-100BZ: 2.7 litres

IM-100Z-23: 2.7 litres

IM-130BZ: 2.7 litres

IM-130Z-23: 2.7 litres

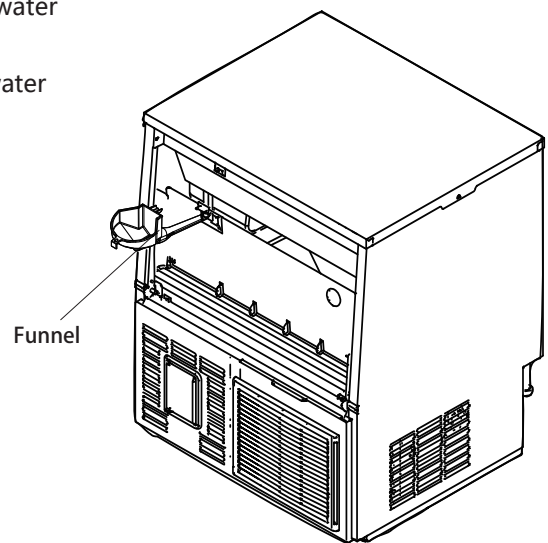

5) Add the appropriate amount of liquid medicine to the funnel mouth (add the appropriate amount of liquid medicine according to different models), the input of liquid medicine indication appears.

6) After putting in the liquid medicine, press the "Maintenance 2" button (1 second), and the ice machine will be cleaned immediately, and the display will display "□□", or the ice machine can automatically start cleaning 15 minutes after the liquid medicine instruction appears.

7) Cover the silicone plug and close the refrigerator door.

8) The ice machine will automatically carry out the cleaning and rinsing process, which takes about 80min.

9) The ice maker will automatically switch to normal ice making mode after the whole cleaning step is over.

#### **⚠ WARNING**

If the ice made after the automated chemical cleaning tastes wrong, immediately stop using the icemaker and call for service.

## NOTICE

After cleaning, be sure to place the air filter back in position.

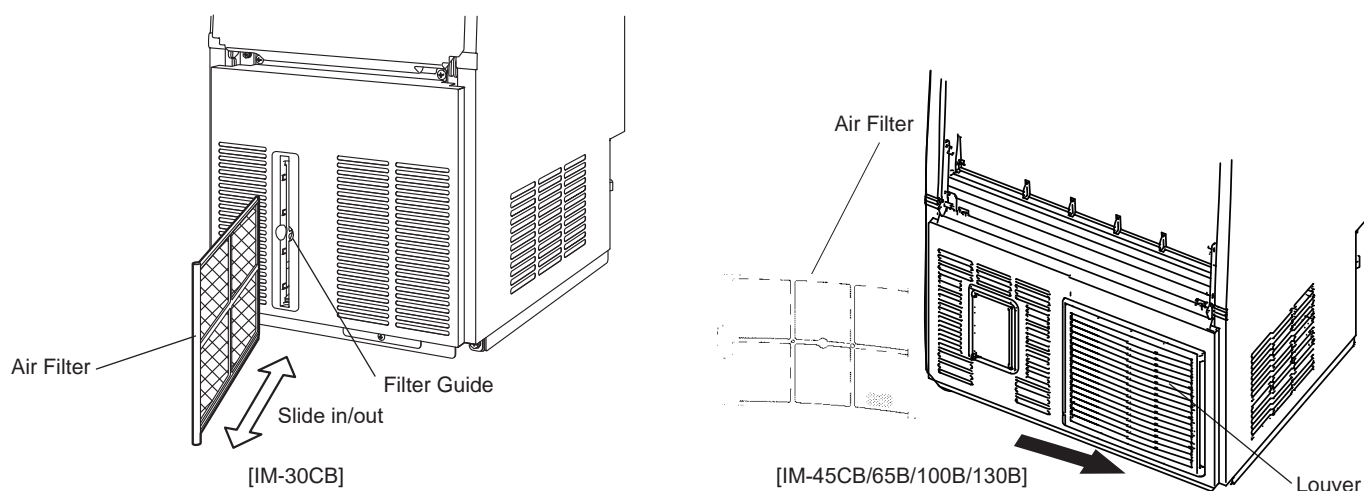

## 2. BEFORE CALLING FOR SERVICE

### ⚠ WARNING

Do not damage the refrigerant circuit.

If the icemaker does not work properly or does not work at all and no error code is indicated on the display, before calling for service, check that:

- \* The power is supplied to the unit.
- \* The water is turned on.
- \* The air filter is clean.

For further assistance or advice, contact your local Hoshizaki service agent.

## 3. DISPOSAL

Comply with local regulations regarding disposal of this appliance and its refrigerant gas. Before you scrap the appliance, take off the door to prevent children trapped.

### IMPORTANT



The insulation foaming agent used for the unit body contains flammable gas cyclopentane. With this in mind, dispose of the product properly.

## 4. WARRANTY

Hoshizaki warrants to the original owner/user that all Hoshizaki branded products shall be free of defects in material and/or workmanship for the duration of the "warranty period". The warranty shall be effective for two years from the date of installation. Hoshizaki's liability under the terms of the warranty are limited and shall exclude routine servicing, cleaning, essential maintenance and/or repairs occasioned by misuse and installations not in accordance with Hoshizaki guidelines.

Warranty repairs should be completed by an approved Hoshizaki dealer or service agency using genuine Hoshizaki components.

To obtain full details of your warranty and approved service agency, please contact your dealer/supplier, or the nearest Hoshizaki Service office.

# ENGLISH

## SPECIFICATIONS

Model	IM-65BZ-25	IM-65BZ	IM-45CBZ
Type	Air-cooled, cube ice	Air-cooled, cube ice	Air-cooled, cube ice
Power Supply	1 phase 220 - 240V 50Hz	1 phase 220 - 240V 50Hz	1 phase 220 - 240V 50Hz
Electric Consumption	390W	390W	310W
Ice Production per 24h	58kg (5mm) / 59kg (15mm) (ambient 10°C, water 10°C)	65kg (5mm) / 70kg (15mm) (ambient 10°C, water 10°C)	45kg (5mm) / 47kg (15mm) (ambient 10°C, water 10°C)
Dimensions	660mm(W) x 589mm(D) x 800mm(H)	660mm(W) x 570mm(D) x 800mm(H)	660mm(W) x 570mm(D) x 695mm(H)
Refrigerant	R134a, 260g	R134a, 260g	R134a, 160g
Weight	Net: 60kg (Gross: 74kg)	Net: 60kg (Gross: 74kg)	Net: 52kg (Gross: 65kg)
Ambient Temp	1 - 40°C	1 - 40°C	1 - 40°C
Water Supply Temp	5 - 35°C	5 - 35°C	5 - 35°C
Water Supply Pressure	0.07 - 0.78 MPa (0.7 - 8 bar)	0.07 - 0.78 MPa (0.7 - 8 bar)	0.07 - 0.78 MPa (0.7 - 8 bar)
Voltage Range	Rated voltage $\pm$ 6%	Rated voltage $\pm$ 6%	Rated voltage $\pm$ 6%

Model	IM-45CBZ-25	IM-30CBZ	IM-30CBZ-25
Type	Air-cooled, cube ice	Air-cooled, cube ice	Air-cooled, cube ice
Power Supply	1 phase 220 - 240V 50Hz	1 phase 220 - 240V 50Hz	1 phase 220 - 240V 50Hz
Electric Consumption	310W	250W	250W
Ice Production per 24h	41kg (5mm) / 48kg (15mm) (ambient 10°C, water 10°C)	27kg (5mm) / 30kg (15mm) (ambient 10°C, water 10°C)	25kg (5mm) / 30kg (15mm) (ambient 10°C, water 10°C)
Dimensions	660mm(W) x 570mm(D) x 695mm(H)	398mm(W) x 510mm(D) x 695mm(H)	398mm(W) x 510mm(D) x 695mm(H)
Refrigerant	R134a, 160g	R134a, 130g	R134a, 130g
Weight	Net: 52kg (Gross: 65kg)	Net: 39kg (Gross: 49kg)	Net: 39kg (Gross: 49kg)
Ambient Temp	1 - 40°C	1 - 40°C	1 - 40°C
Water Supply Temp	5 - 35°C	5 - 35°C	5 - 35°C
Water Supply Pressure	0.07 - 0.78 MPa (0.7 - 8 bar)	0.07 - 0.78 MPa (0.7 - 8 bar)	0.07 - 0.78 MPa (0.7 - 8 bar)
Voltage Range	Rated voltage $\pm$ 6%	Rated voltage $\pm$ 6%	Rated voltage $\pm$ 6%

Model	IM-100BZ	IM-130BZ	IM-100BZ-23
Type	Air-cooled, cube ice	Air-cooled, cube ice	Air-cooled, cube ice
Power Supply	1 phase 220 - 240V 50Hz	1 phase 220 - 240V 50Hz	1 phase 220 - 240V 50Hz
Electric Consumption	680W	630W	680W
Ice Production per 24h	100kg (5mm) / 112kg (15mm) (ambient 10°C, water 10°C)	120kg (5mm) / 126kg (15mm) (ambient 10°C, water 10°C)	90kg (5mm) / 96kg (15mm) (ambient 10°C, water 10°C)
Dimensions	660mm(W) x 570mm(D) x 1200mm(H)	660mm(W) x 570mm(D) x 1200mm(H)	660mm(W) x 570mm(D) x 1200mm(H)
Refrigerant	R404A, 400g	R404A, 350g	R404A, 400g
Weight	Net: 76kg (Gross: 95kg)	Net: 79kg (Gross: 98kg)	Net: 76kg (Gross: 95kg)
Ambient Temp	1 - 40°C	1 - 40°C	1 - 40°C
Water Supply Temp	5 - 35°C	5 - 35°C	5 - 35°C
Water Supply Pressure	0.07 - 0.78 MPa (0.7 - 8 bar)	0.07 - 0.78 MPa (0.7 - 8 bar)	0.07 - 0.78 MPa (0.7 - 8 bar)
Voltage Range	Rated voltage $\pm$ 6%	Rated voltage $\pm$ 6%	Rated voltage $\pm$ 6%

Note: The above specifications are for the representative models.

# ENGLISH

---

## SPECIFICATIONS

Model	IM-130BZ-23
Type	Air-cooled, cube ice
Power Supply	1 phase 220 - 240V 50Hz
Electric Consumption	660W
Ice Production per 24h	100kg (5mm) / 106kg (15mm) (ambient 10°C, water 10°C)
Dimensions	660mm(W) x 570mm(D) x 1200mm(H)
Refrigerant	R404A, 450g
Weight	Net: 79kg (Gross: 98kg)
Ambient Temp	1 - 40°C
Water Supply Temp	5 - 35°C
Water Supply Pressure	0.07 - 0.78 MPa (0.7 - 8 bar)
Voltage Range	Rated voltage $\pm$ 6%

Note: The above specifications are for the representative models.



联系人:

**星崎商厨智造(苏州)有限公司**  
江苏省苏州工业园区青丘街15号  
邮编: 215126  
电话: +86 512-62807850  
传真: +86 512-62807860



专用微信公众号

**星崎香港有限公司**  
香港九龍觀塘巧明街95號世達中心17樓G室  
电话: +852 2866-2108  
传真: +852 2866-2109

**Hoshizaki Singapore Pte Ltd**  
18 Boon Lay Way #07-142 Tradehub 21, Singapore 609966  
Tel: +65 6225-2612  
Fax: +65 6225-3219

Contact:

**Hoshizaki China Corporation**  
No. 15 Qingqiu Street, Suzhou Industrial Park,  
Suzhou 215126 China  
Tel: +86 512-62807850  
Fax: +86 512-62807860

**Hoshizaki Hong Kong Co., Limited**  
Unit G, 17/F, World Tech Center, No. 95 How Ming Street,  
Kwun Tong, Kowloon, Hong Kong  
Tel: +852 2866-2108  
Fax: +852 2866-2109

**Hoshizaki Singapore Pte Ltd**  
18 Boon Lay Way #07-142 Tradehub 21, Singapore 609966  
Tel: +65 6225-2612  
Fax: +65 6225-3219

---

生产商:

**星崎商厨智造(苏州)有限公司**  
江苏省苏州工业园区青丘街15号  
电话: +86 512-62807850  
传真: +86 512-62807860

邮编: 215126

Manufacturer:

**HOSHIZAKI CHINA CORPORATION**  
No. 15 Qingqiu Street, Suzhou Industrial Park, Suzhou 215126 China  
Tel: +86 512-62807850  
Fax: +86 512-62807860

**HOSHIZAKI**